



BS 6920
CERTIFIED

TZW Karlsruhe
Prüfstelle Wasser

TZW



aquaflex...



ADD300-12"

FINE BUBBLE

DISC DIFFUSER

TECHNICAL DATA SHEET

ADD300-12" FINE BUBBLE DISC DIFFUSER

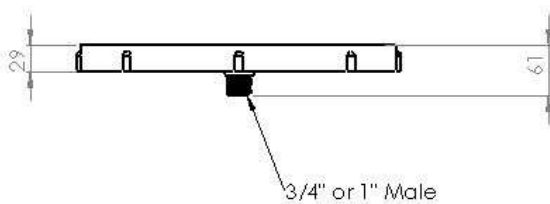
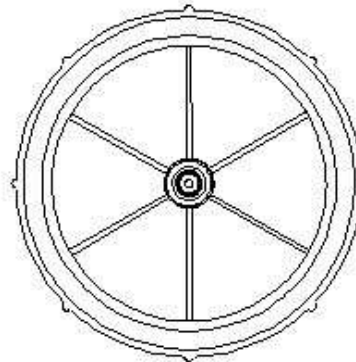
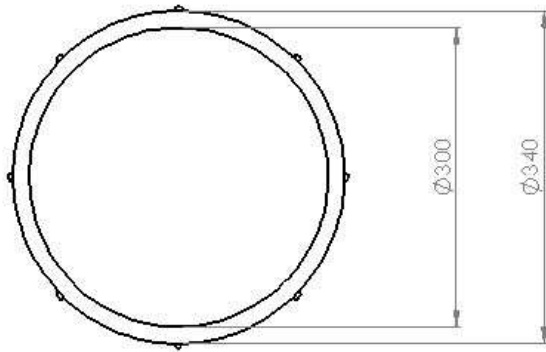

Qualities Of aquaflex Fine Bubble Disc Diffuser

- Polypropylene (30% PP GFR) body and membrane from EPDM rubber or Silicon.
- membrane has conically designed pores to have best oxygen transfer with bubbles of an average diameter <3 mm, and best sealing when airflow is cut off. Membrane has thicker center without pores which additionally covers inlet and eliminate clogging.
- High oxygen transfer efficiency even with low air capacity.

ADD300-12" FINE BUBBLE DISC DIFFUSER



AQUAFLEX

SINCE 1974
IN MORE THAN 65 COUNTRIES
WE GIVE LIFE TO THE WATER.



CONTACT US

KAYAPA MAH. ORKIDE CAD. NO : 1/1 NILUFER BURSA
TURKEY

+90 (850) 888 73 02 / +90 (224) 441 12 08 - 09

info@aquaflex.com.tr / export@aquaflex.com.tr

www.aquaflex.com.tr